

Signature® Choral Riser

- 3-Step 098D053 210 lbs (95 kg).
- 4-Step 098D054 262 lbs (119 kg).
- Load rating of 150 lbs live load capacity per square foot (732 kg capacity per square meter).
- Portable units are designed for one-person mobility and setup.
- 3-Step Riser storage depth is 28½" deep x 68" high x 72" long (72 x 173 x 183 cm).
- 4-Step Riser storage depth is 28½" deep x 79" high x 78" long (72 x 201 x 198 cm).
- Nesting of additional units reduces storage depth by 2" (5 cm).
- Optional side rail can be removed with the mounting brackets left attached during storage.
- Step supports are welded steel for maximum stability and strength.
- Permanently attached back rails have a black powder-coat paint finish for maximum safety and durability.
- Optional side rails have a black powder-coat paint finish and attach to the riser and back rail.
- Steps are covered with grey 100% olefin double tuft carpet.
- Units have built-in 4" (10 cm) swivel action wheels for maneuvering in tight spaces.
- Designed for in-facility use.
- Available in 72" (183 cm) wide 3-Step Riser and 78" (199 cm) wide 4-Step Riser. Steps are 18" (46 cm) deep.
- The rise of each step is 8" (20 cm).
- Easily fits through standard doorways.
- Built-in reversibility without the use of tools allows for straight or semi-circular configuration.
- Optional Side Rail Accessory (set of 2) 098D541 62 lbs (28 kg) is designed for risers set-up in the standard configuration.
- Optional Side Rail Extension Kit 098D231 is available for risers set-up in the reverse configuration.
- Steps attach with a wing nut design that provides the safety of bolted construction to ease changing step orientation without tools.
- 42" (107 cm) high permanently attached back rail meets OSHA standard.
- Both 3-Step and 4-Step models fold with back rail attached.
- Fifteen-year warranty. Patented design.
- Ships unassembled in two cartons.
- Assembly is required with all necessary tools included.
- Assembly time is estimated at 30 to 45 minutes for the first unit and 20 to 30 minutes for each additional unit depending on which unit is being assembled.
- Assembly videos are available at www.wengercorp.com.
- Environmental attributes and LEED compliance for this product can be found at www.wengercorp.com/GREEN or by contacting your Wenger representative.

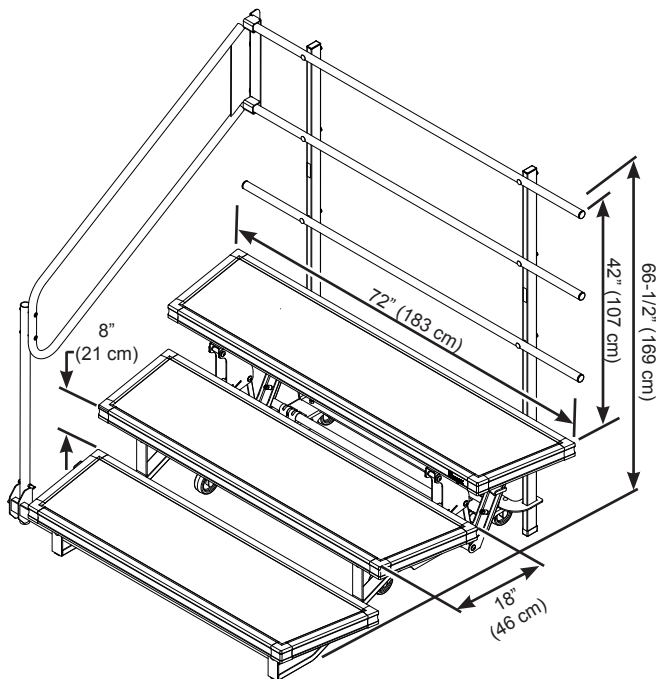

3-Step Riser with Optional Side Rail

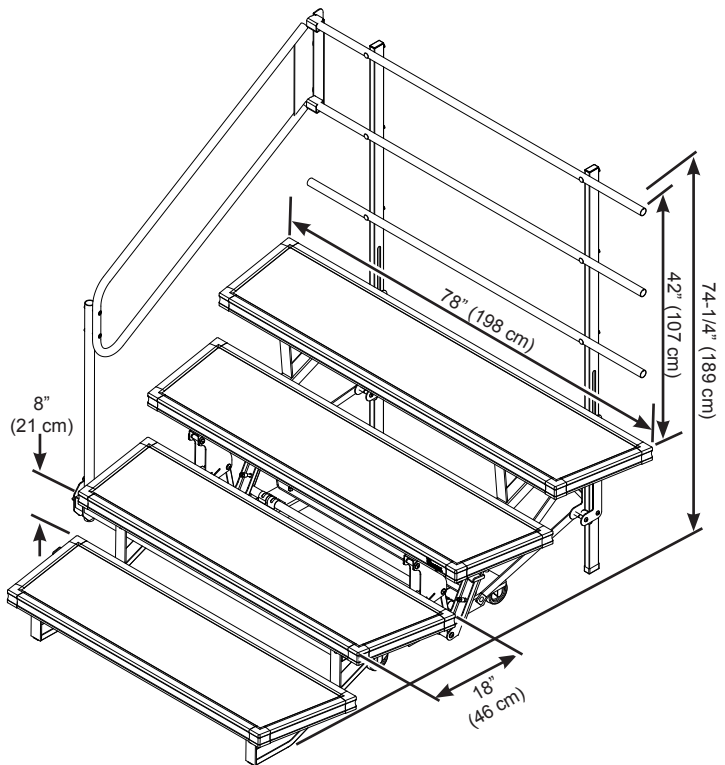

4-Step Riser with Optional Side Rail

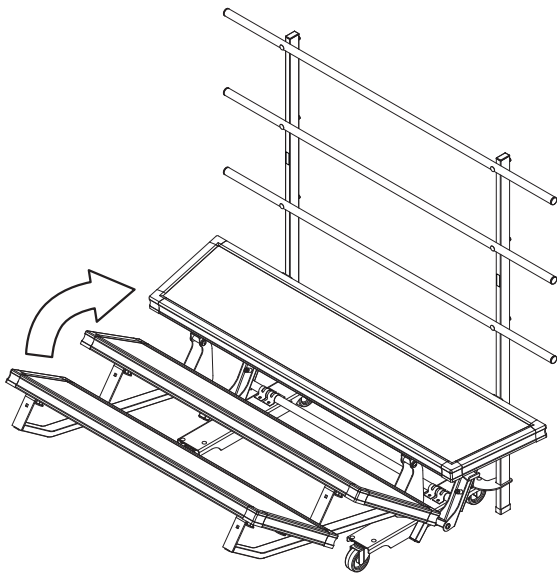
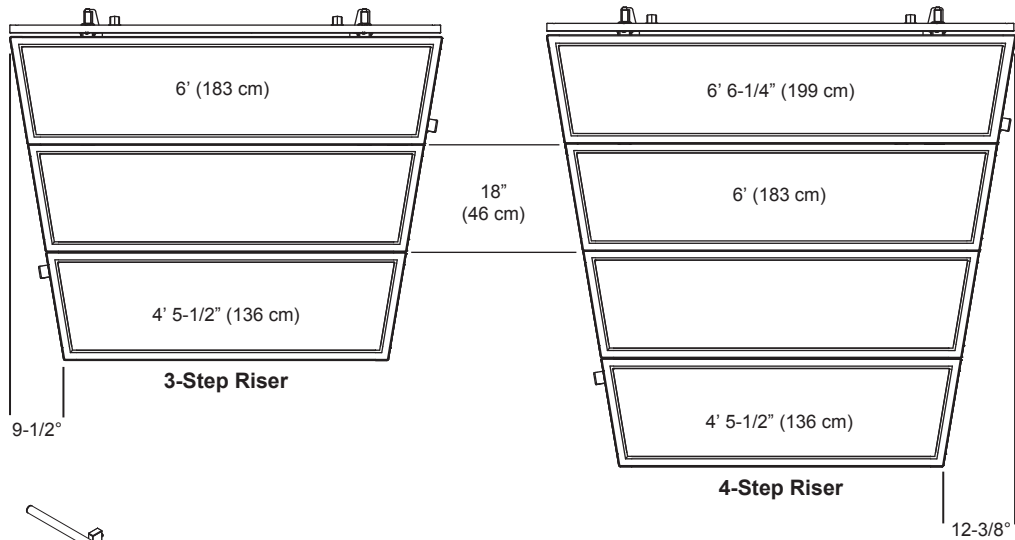

Folds into Storage Position

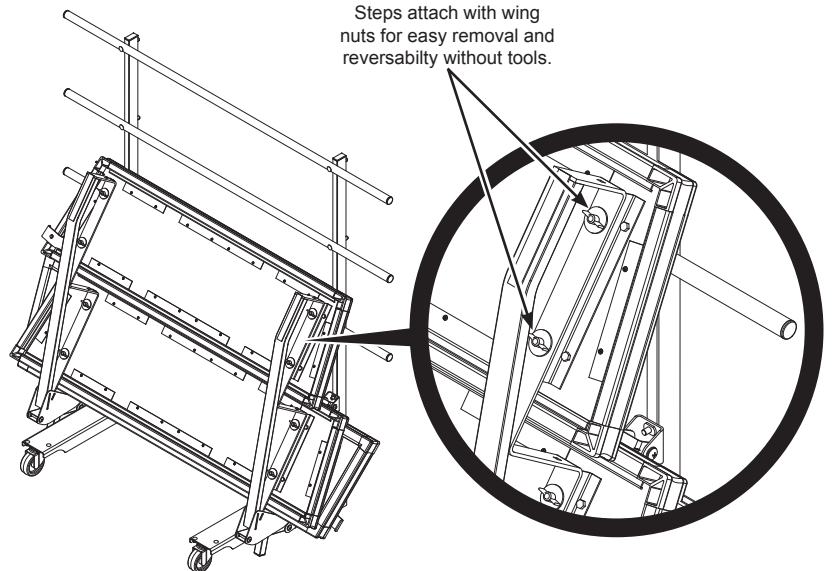

Steps attach with wing nuts for easy removal and reversibility without tools.

Storage and Rolling Position



© 2017 Wenger Corporation
USA/2017-01/W



WENGER CORPORATION

Phone **800.4WENGER (493-6437)** Worldwide **1.507.455.4100** | Fax **507.455.4258** Worldwide **1.507.774.8576**
Parts & Service **800.887.7145** | Canada Office **800.268.0148** | Web **wengercorp.com** | 555 Park Drive, PO Box 448 | Owatonna | MN 55060-0448

GEARBOSS

Phone **800.493.6437** | email **gearboss@wengercorp.com** | Web **gearboss.com** | 555 Park Drive, PO Box 448 | Owatonna | MN 55060-0448

JR CLANCY

Phone **800-836-1885** Worldwide **1.315.451.3440** | Fax **877.836.1885** Worldwide **1.315.451.1766** | Web **jrclancy.com**
7041 Interstate Island Road | Syracuse | NY 13209-9713